

Central Vacuum System INSTALLATION MANUAL



Congratulations, you have joined the growing number of households to enjoy the many benefits of owning a central vacuum system. This booklet contains an overview of how to install a central vacuum system.

TOOLS REQUIRED...

- 1/2" Right Angle Electric Drill
- 2 1/2" Hole Gutter
- 1/4" Masonry Bit
- 1/8" Drill Bit Hack Saw or Small Hand Saw
- Pocket or Utility Knife
- Steel Measuring Tape
- Screw Driver (Philips)
- Screw Driver (Slot)
- Electrical Tape and Connectors
- Wire Coat Hanger

Installing a central vacuum system is a straightforward do-it-yourself project that doesn't require special tools or skills. The procedure is quite simple if you take your time and follow the instructions carefully. Always fully consider the implications before you cut into a wall. Make sure you have chosen the right location and are not cutting into any hidden electrical wires or plumbing.



Repurposed by M.D. Manufacturing for internet use by permission of Vaculine (Canplas Industries in Ontario, Canada). Vaculine manufactures high quality central vacuum fittings at exacting standards to provide positive seals, easy installation and superior air flow characteristics.

Plan Ahead!

Planning is the key to the successful installation of a central vacuum system. A balance between the best locations for the inlet valves and the practicality of installing in these locations must be obtained. With a little ingenuity most locations can be reached.

The Power Unit Location

The power unit can be located in the garage, basement, utility room or any other area that is dry and remote enough that living areas will not be affected by the sound of the electric motor. The unit must be mounted within three feet of an electrical outlet. Electrical specifications of the power unit should be checked to avoid overloading the circuit. The unit should be mounted so that it is out of the way but still accessible for emptying. If the system is to be exhausted to the outdoors the power unit should be located on an exterior wall. Venting to areas such as patios and entranceways should be avoided.

** Vacuums must breath...do not enclose. If the unit is to be located in a closet or utility room it must be vented. Louvered doors fulfill this purpose. A muffler can, of course be used to minimize noise.

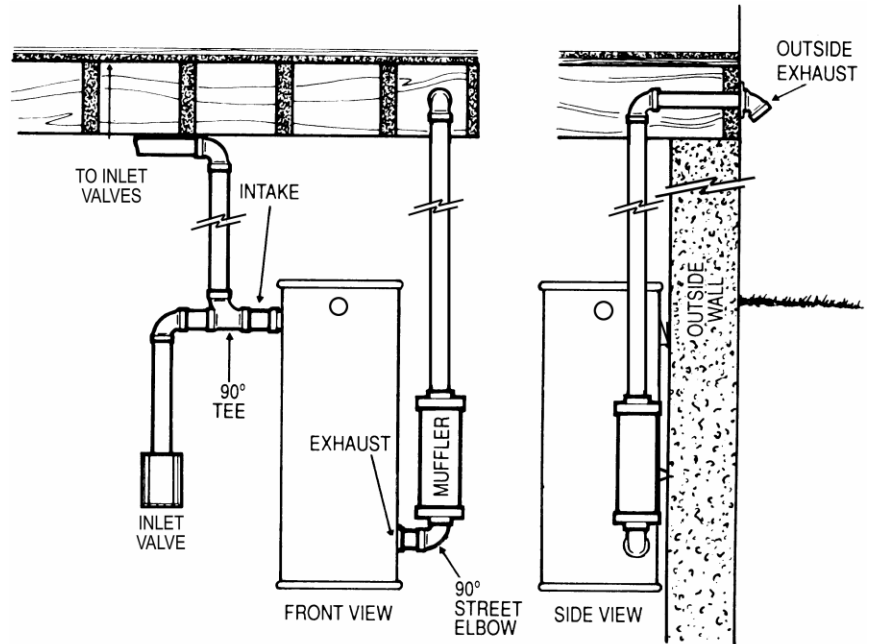

Inlet Valve Locations

Correctly positioned inlet valves will ensure trouble-free vacuuming over the many years of service that will be received from a central vacuum system. The hose must be able to reach every corner of the house and go around furniture to get there. Drapes, closets and ceiling corners all must be reached. Central locations such as hallways, beside doors and adjacent to the bottom of staircases are ideal. Areas such as behind furniture or behind doors should be avoided. A thirty-foot

string or the hose itself can be used to help plan the layout. If working with 1/4' scale blueprints a seven-inch string can be used to represent the hose. If an electrical beater brush is to be used at present or in the future the inlet valve should be located within five feet of an electrical outlet. Air-turbine driven beater brush heads do not require electricity and thus allow more flexibility when choosing inlet valve locations.

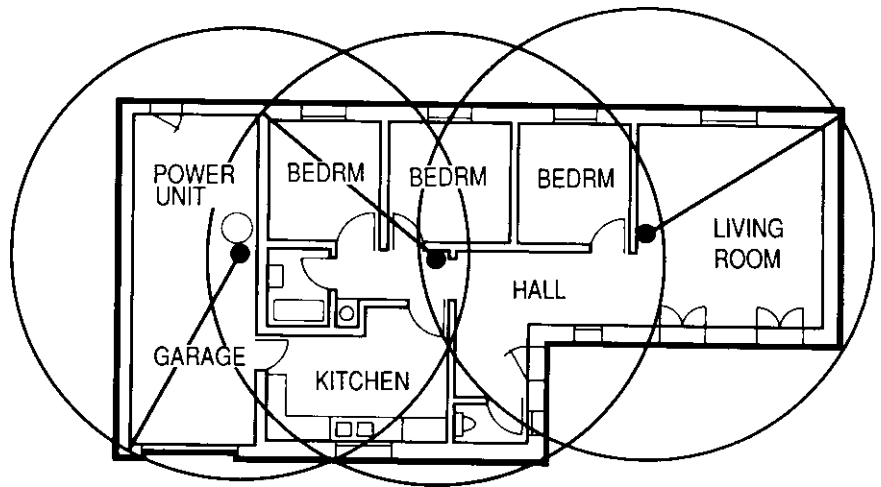

Planning the Piping System

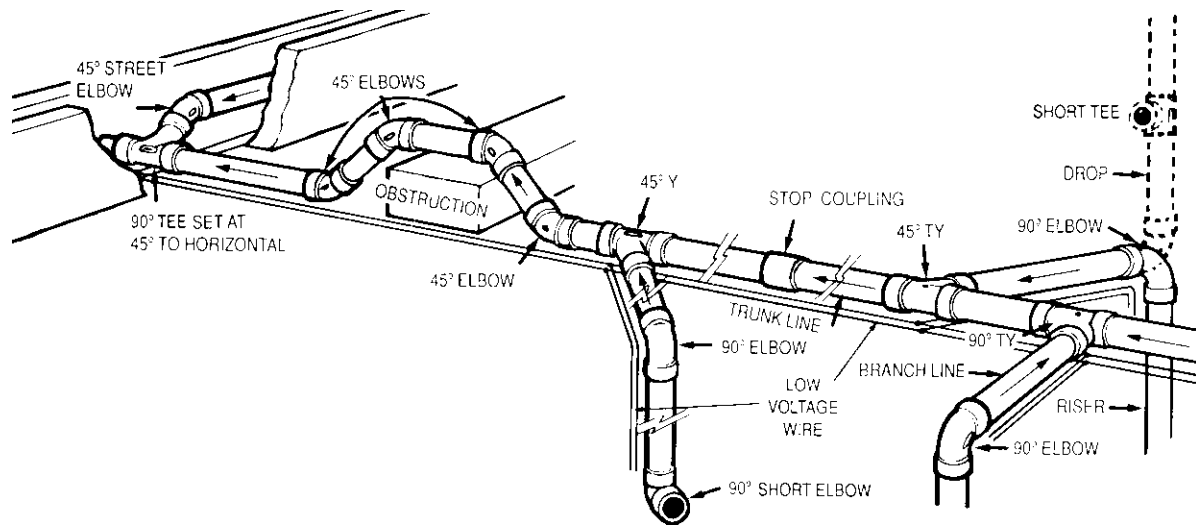

The amount of airflow that reaches the hose is dependent on the efficiency of the layout of the tubing system. Lines are to be kept as straight as possible. Tight 90 degree fittings are to be used only at inlet valve locations and sweep 90's used in all other applications.

1. The Trunk Line

The trunk line connects the furthest inlet valve to the power unit. Branch lines flowing into the trunk line will connect all other inlet valves. If the basement is unfinished the trunk line is best run beneath the joists in the basement ceiling. The upper floors can be accessed through closets, cold air return ducts or in partition walls. Alternatively the trunk line could run straight up to the attic and service the floors beneath by branch lines dropping through closet ceilings or partition walls. The location of the trunk line will greatly depend on the construction of the house and the location of the power unit.

2. Branch Lines

Branch lines join the remaining inlet valves to the trunk line. As with the trunk line these lines

should be kept as straight as possible. Forty-five degree fittings should be used to avoid sharp corners (90 degree fittings) when possible. Airflow direction should always be considered when installing branch lines.

Avoid Gravity Drops!

A branch line located directly below an overhead trunk line will accumulate dirt due to the effects of gravity. The result will be a pile of dirt at the base of the inlet valve every time it is opened. To avoid this situation the following techniques should be used.

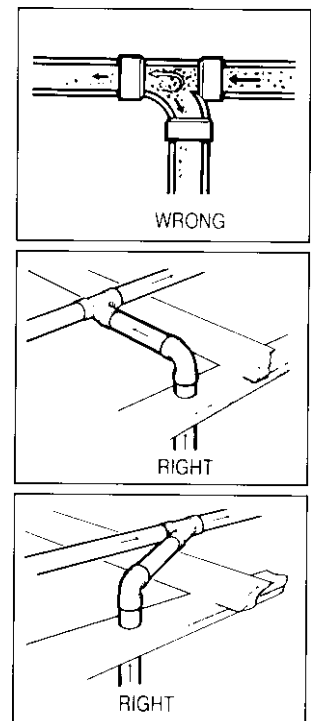

Cutting and Cementing PVC Tubing and Fittings

Measuring: When sizing a length of tube, measurements should be taken from the base of the pipe-stop on the inside of the fitting. As each section of tubing is cut, it should be dry fitted before the next measurement is taken.

Cutting: The tubing should be cut as straight and square as possible. A miter box should be used if available. All rough edges must be removed with a utility knife or coarse sand paper.

Dry Fitting: Once all the pieces are cut they should be dry fitted to check for correct fit. The markings on the fittings can be utilized to assure proper alignment.

Gluing: PVC solvent cement actually welds the fitting to the tubing. A chemical reaction perma-

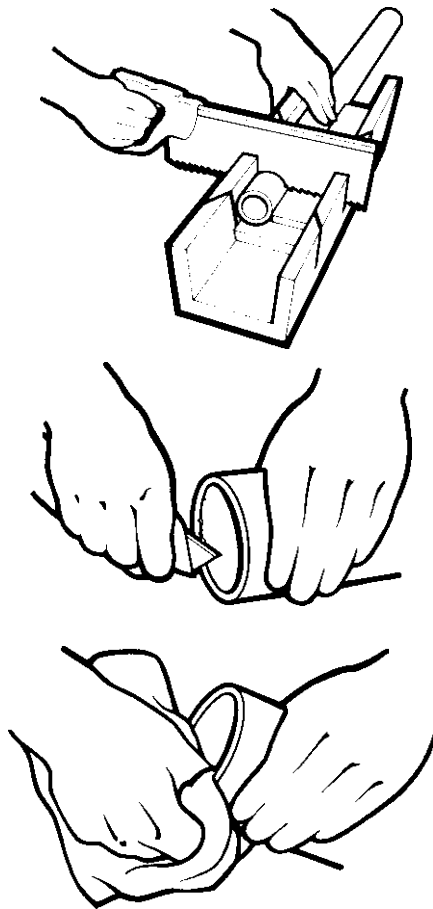

nently joins the molecules from each surface to produce an airtight seal.

Before cementing, both the tubing and the fitting must be free of PVC burrs, dirt and grime. The components should be wiped with a clean cloth if necessary. Cement should be applied to the tubing only as cement applied to the fitting will be pushed ahead and create a rough bead on the inside of the fitting. This bead will reduce airflow and could cause a clog. The tubing should be inserted all the way into the fitting and twisted a quarter turn to evenly distribute the cement. All excess cement should be removed with a rag. The glue should be allowed several hours to set before the vacuum system is used.

Low Voltage Wire

One of the greatest benefits of central vacuum systems is that the power unit is turned on and off automatically. Every power unit has an on/off switch that is activated by completing a circuit at the inlet valves. Simply inserting the hose in the inlet valve turns on the power unit.

To facilitate this, low voltage wire must follow the tubing system. At the junction of a branch line and the trunk line the wires can be spliced together as demonstrated in the figure.

There must be an uninterrupted route from each inlet valve to the power unit. The wire should be attached to the tubing with the wire ties at least every four feet.

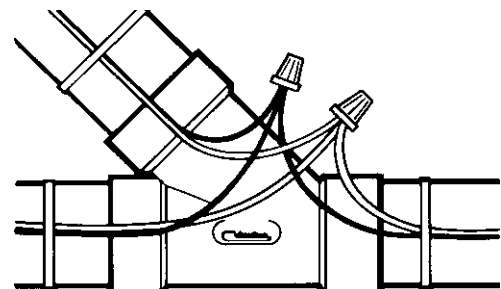

INSTALLATION Existing Home

In a Partition Wall

Determine the desired location of the inlet valve and locate the point directly below the center of the proposed location. Holding the drill vertical and as close to the wall as possible drill a small

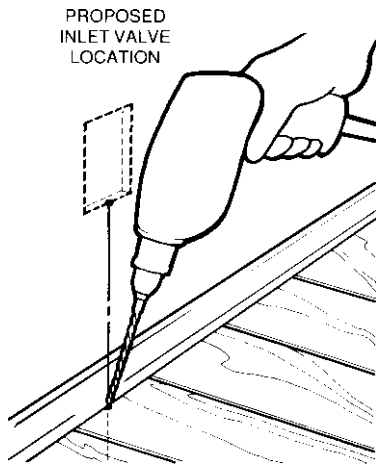

pilot hole through the floor and sub floor. The straight section of a wire coat hanger cut at an angle makes a good pilot hole drill bit. (Be careful not to snag carpeting.)

Locate this pilot hole from beneath and measure over approximately 2 1/4

(1/2 for drywall + 1 3/4" to center of the sole plate, that is the base of the wall) adding extra for the thickness of any baseboards. Using a 2 1/2" hole cutter, drill upwards through the flooring and the sole plate. Using a flashlight inspect the interior of the wall to make sure there are no obstructions. Alternatively a piece of tubing can be used to probe for obstructions.

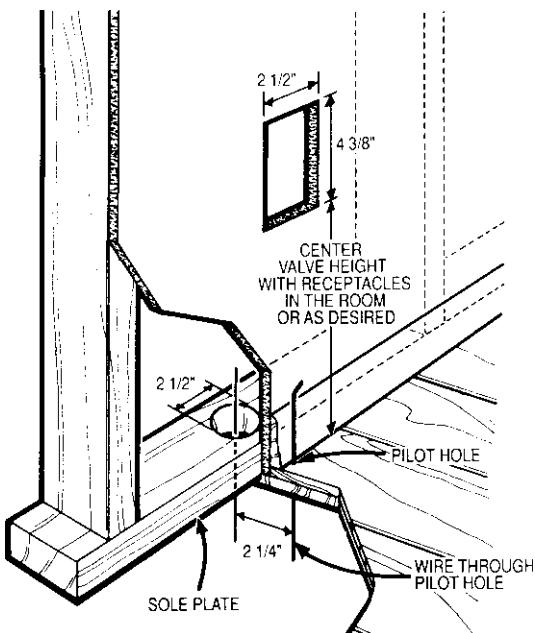

Having determined the location is suitable cut a 2 1/2" X 4 3/8" hole in the wall at the desired inlet valve location. Remove the side

portion of the mounting plate by cutting off the plastic with side cutters. Tape low voltage wire to the end of a sufficiently long piece of tubing and pass it up from beneath. If the trunk line is in the attic, tie a weight to the end of the low voltage wire and lower it through the opening. Remove the wire and pass it through the upper hole in the trimmed mounting plate. Bare an inch of both wire leads and wrap them around the lugs on the back of the valve in a clockwise direction. Tighten the lugs with a Philips screwdriver. Run your wire in the walls to the valves before you run the pipe.

Apply cement to the spigot on the back of the mounting plate and attach a short 90 degree fitting oriented in the appropriate direction. Tilt the mounting plate forward and angle it into the hole in the wall. Center the mounting plate in the hole and pull outward.

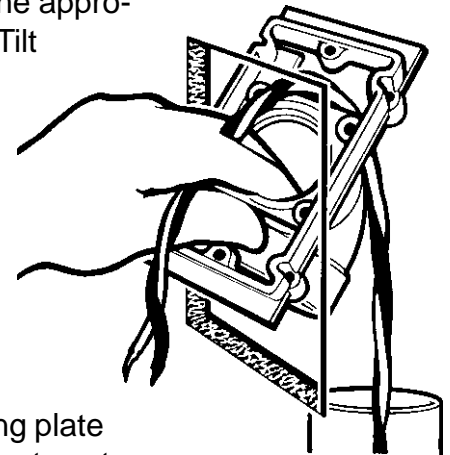

Hold the mounting plate in place with a bent coat hanger. Open the valve lid and slide the valve spigot first over the end of the coat hanger. Keep tension on the coat hanger while inserting the valve into the mounting plate with a twisting motion. Do not use glue; the built-in mounting plate gasket will provide a positive seal. Align the screw holes in the valve with those in the mounting plate. Using the screws provided secure the valve in place. Use the extra short screw if the longer screw is going to interfere with the tubing behind. Do not over tighten.

On the floor below apply glue to an adequate length of tubing and aim it upwards through the hole in the sole plate and into the short 90 degree fitting on the back of the mounting plate. Join this branch line to the trunk line using a sweep tee. Note the airflow direction of the tee. When strapping your wire to the pipe, leave several inches loose at the valve. This facilitates servicing the valve by having slack in the wire.

If the inlet valve is to be serviced from the attic, shorter pieces of tubing joined by couplings may be

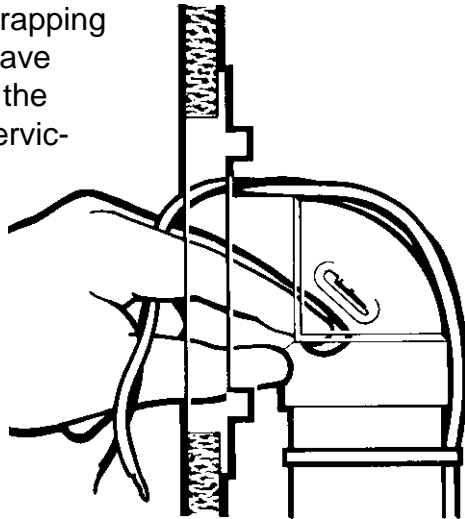

required due to overhead space restrictions. Precut these pieces and work quickly to prevent the cement on the end of the tubing from drying before it reaches the fitting at the valve below.

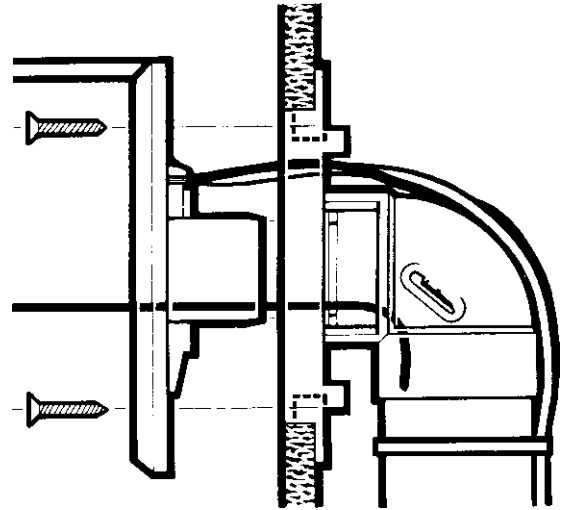

Through a Closet

If obstructions make it impossible to run vertical tube lines through partition walls the best and easiest alternative is to go through the insides of closets, particularly when a closet on the second floor is directly above a closet on the main floor. Look for other possibilities as well, such as return air areas or under stairs.

Drill a horizontal pilot hole through the center of a suitable inlet valve location on the wall. Probe for hidden obstructions in the wall with a bent piece of coat hanger. With the pilot hole as a center drill a 2 1/2" hole through both sides of the wall. Using a keyhole saw cut a 2 1/2" x 4 3/8" hole in the outside wall (the side that will have the valve).

Feed the low voltage wire through from the inside of the closet, thread it through the top hole of a trimmed mounting plate and attach it to the lugs on the back of the valve. Instead of a 90-degree fitting that was used in a partition wall, glue a coupling on the spigot of the mounting plate. Attach this assembly to the wall as

described above in the partition wall section. Then, from inside the closet, insert a short piece of tubing into the coupling. Dry fit a tight 90-degree fitting pointed in the direction of the trunk line below or above. Cut a 2 1/2" hole below or above the fitting and feed a length of tubing through to the trunk line. When you are satisfied with the fit, permanently glue the fittings in place.

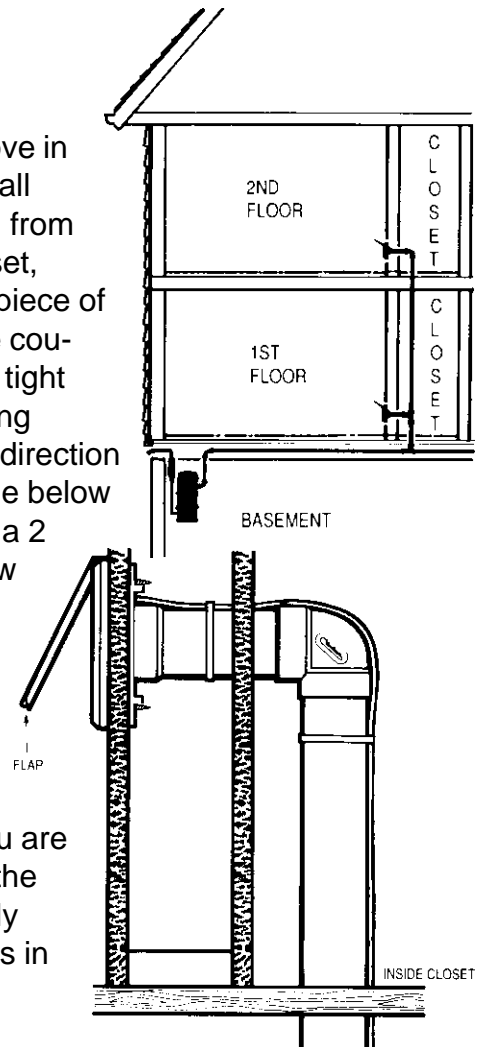

Floor Mounted Inlet Valves

While the normal installation on inlet valves is in partition walls, occasionally one must be installed in the floor. In this case the location for the inlet valve should be about two inches from the wall and not in a high traffic area. As with wall installations use a pilot hole drill to make sure the location is clear of obstructions below. Cut a hole that is 2 1/2' x 4 3/8' in the floor. In the case of linoleum or uncovered floors the mounting plate will be installed from below. If the floor is carpeted cut a hole in the carpet with a utility knife and slip the untrimmed mounting plate under the carpet. Fasten the mounting plate to the floor with screws. A coupling and a short piece of tubing may be required as a spacer between the mounting plate and the 90 degree fitting below.

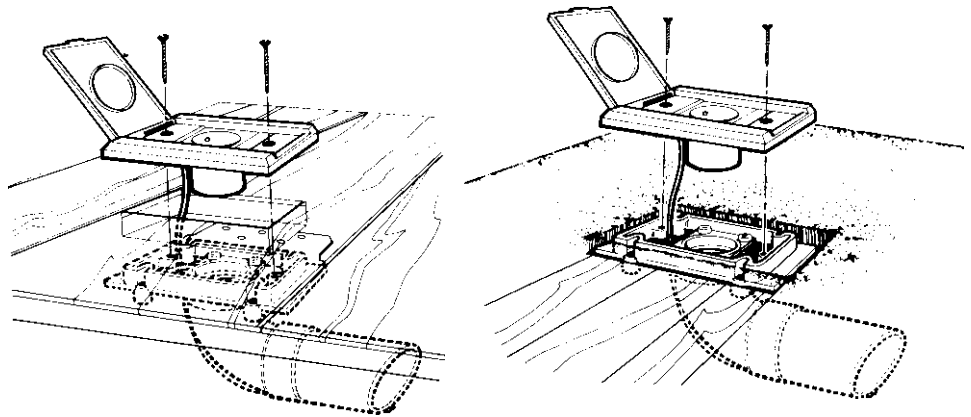

Special Applications for Existing Homes:

Houses with Slab Floors and Flat Roofs

Houses with flat roofs and slab floors require all inlet valves to be installed in exterior walls and branch lines to be run outside of the house. The tubing system can be run underground or under the eaves of the house. If the power unit is to be mounted outside it must be housed in a weatherproof cabinet that has adequate air vents.

Locate and install the inlet valves in much the same way as for closet installations. Use a tight 90-degree fitting to keep the tubing close to the exterior wall. Seal the edges of the hole in the exterior wall with caulking.

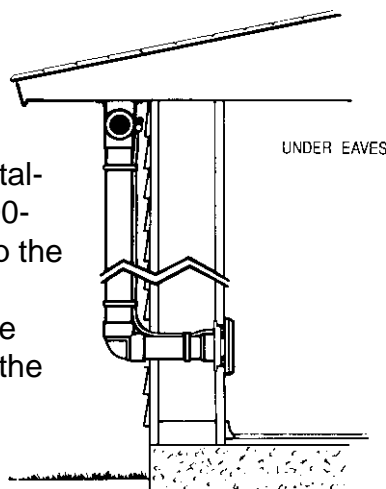

If the tubing system is to run under the eaves pipe straps must support the tubing at least every six feet. On

vertical sections carefully wire tie the low voltage wire behind the tubing.

If the tubing is to be buried underground, dig a trench 12 to 18 inches deep along the side of the house. Fully assemble and test the tubing and low voltage wire before filling in the trench. It is recommended that the low voltage wire installed outside be encased in conduit, which is available at most hardware stores. M.D. Manufacturing recommends running the 2-inch pipe and wire within a 3-inch PVC pipe; this relieves condensation buildup with leads to clogs and protects the wire.

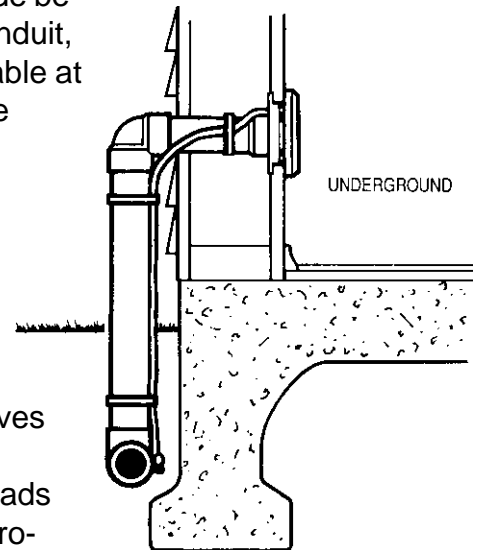

INSTALLATION

New
Construction

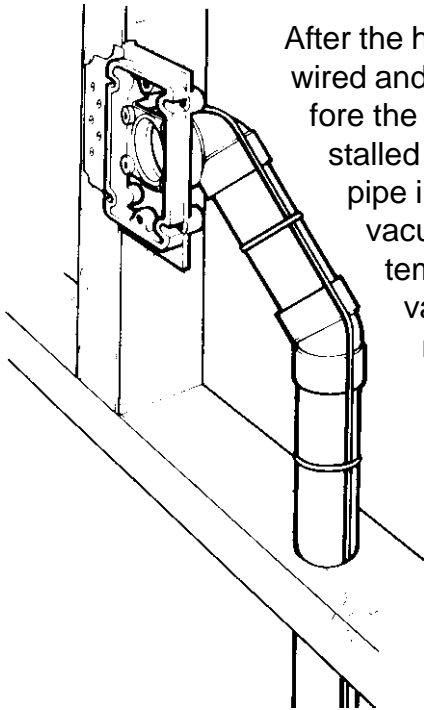

After the house has been wired and plumbed, but before the dry wall is installed is the best time to pipe in a central vacuum tubing system. Locate the inlet valve locations and nail the mounting plate to the nearest stud. Make sure the middle of the mounting

plate is at the same height as the middle of adjacent electrical outlets.

It is best to offset the tubing using a combination of a tight 90 degree fitting and a 45 degree elbow. This will avoid problems of mounting screws puncturing the tubing as well as allowing the hole to be drilled further away from the stud where nails could ruin the hole saw. Drill a 2 1/2" hole in the center of the top or sole plate depending on the location of the trunk line. Attach low voltage wire to the tubing and push the tubing through from the floor below and cement it to the forty-five degree fitting. Leave ten inches of low voltage wire at the mounting plate for valve installation when the house is completed.

Once the house is completed the inlet valves must be installed. Bare a half inch of the low voltage wire leads and wrap them in a clockwise direction around the lugs on the back of the valve. Tighten the lugs with a screwdriver. Using a twisting motion insert the valve into the hole with the hinge at the top of the valve. Do not apply glue; the gasket in the mounting plate will provide a positive seal. If the valve will not

reach the mounting plate ask your dealer for an inlet valve extension. Using the screws supplied, attach the inlet valve to the mounting plate. Use the extra short screw if the longer version is going to penetrate the tubing behind.

Note: Do not over tighten. If a whistling develops during operation slightly loosen the screws.

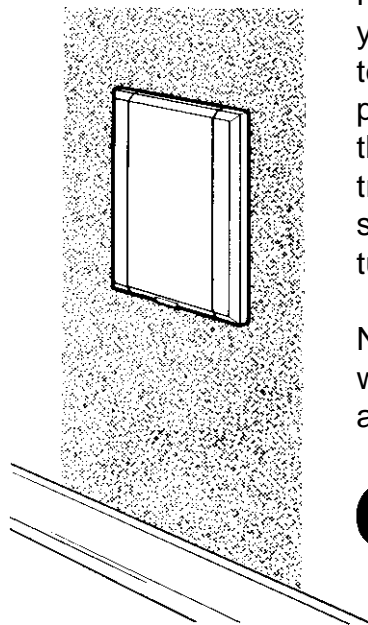
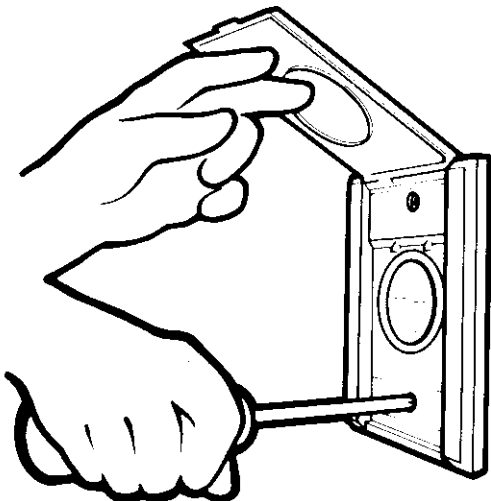
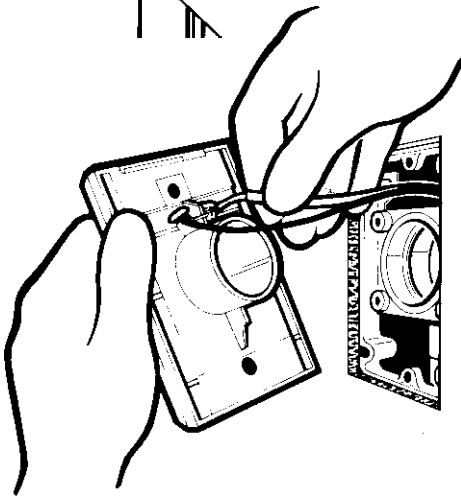

canplas
INDUSTRIES LTD.